

LE BRISE-SOLEIL ORIENTABLE

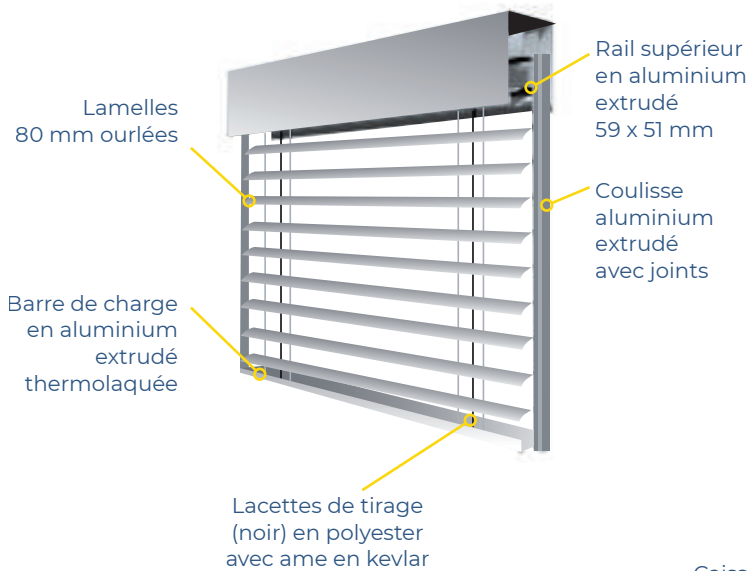

3 VERSIONS...

1. STANDARD



DEUX TYPES DE POSES

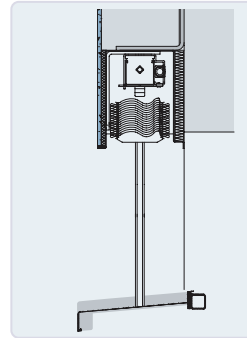

En niche avec empilement des lames au-dessus de la hauteur de baie.

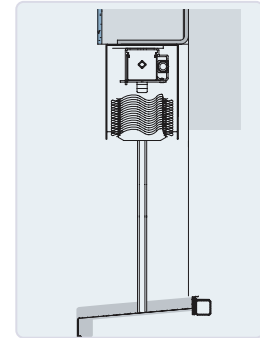

Sous linteau avec empilement inclus dans la hauteur de baie.

DEUX TYPES DE CAISSONS



Caisson en L
- Standard : BL01
- ITE : BL12

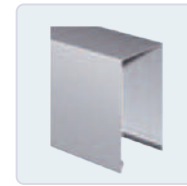

Caisson en U
- Standard : BL06
- ITE : BL31

2. AUTOPORTÉE

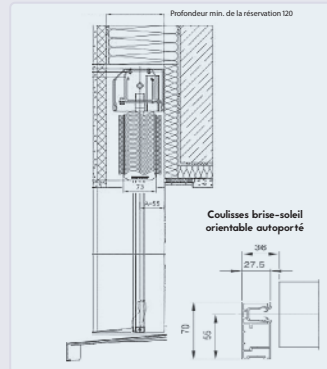

3. RÉNOVATION



COFFRE À PAN COUPÉ

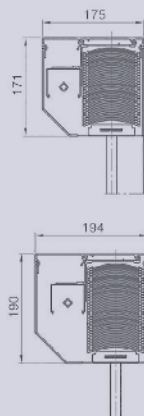

COFFRE ARRONDI

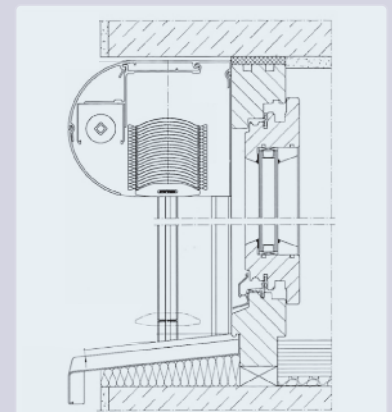
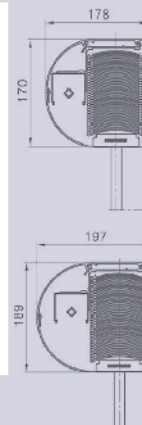

LES LAMES



- > Bonne stabilité
- > Usure et bruit au vent réduites grâce aux œilletons de protection



- > Stabilité augmentée au vent
- > Occultation renforcée grâce aux joints

LES MOTORISATIONS ET COMMANDES

Moteur central filaire SOMFY, par défaut.
Manœuvre en option : Radio io - Somfy, Solaire - Warema.
Chaque BSO est livré avec son point de commande Situio 1 io variation.

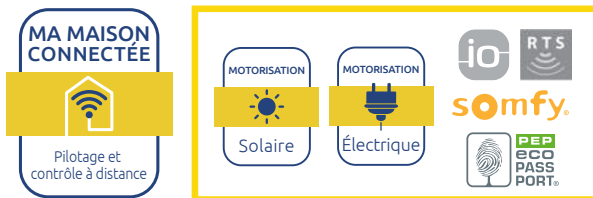

LES COMMANDES RADIO

INDIVIDUELLE



io - Situio 1 io avec variation

GÉNÉRALE



io - Situio 5 io avec variation

LES AUTOMATISMES IO

Capteur extérieur Soleil



Sunis Wire Free io

LES OPTIONS DISPONIBLES

Capteur extérieur Soleil



(sans interface)

Capteur extérieur Soleil & Vent



(Compatible en commande radio et solaire io)

PLUS D'OPTIONS SUR DEMANDE !

LES LIMITES DIMENSIONNELLES

Dimensions max.	STANDARD		AUTOPORTÉ ou RÉNOVATION	
	Lame 80s	Lames Z73 ou Z93	Lame 80s	Lames Z73
Hauteur	5000 mm	4300 mm	4000 mm	4000 mm
Largeur	5000 mm	4500 mm	4000 mm	4000 mm
Surface	20 m ²	15 m ²	16 m ²	15 m ²
Coffres				
Hauteur 2 600	-	-	170	
Hauteur 4 000	-	-	190	

